

## Compressive Strength of Confined Concrete in CCFST Columns

A. Kheyroddin<sup>1</sup>, H. Naderpour<sup>2\*</sup>, M. Ahmadi<sup>3</sup>

1. Professor, Faculty of Civil Engineering, Semnan University, Semnan, Iran.

2. Assistant Professor, Faculty of Civil Engineering, Semnan University, Semnan, Iran.

3. M.Sc., Faculty of Civil Engineering, Semnan University, Semnan, Iran.

Corresponding author: [naderpour@semnan.ac.ir](mailto:naderpour@semnan.ac.ir)

### ARTICLE INFO

Article history:

Received: 17 August 2012

Accepted: 19 May 2013

Keywords:

CCFST Columns

Artificial Neural Network

Confined Concrete

### ABSTRACT

This paper presents a new model for predicting the compressive strength of steel-confined concrete on circular concrete filled steel tube (CCFST) stub columns under axial loading condition based on Artificial Neural Networks (ANNs) using a wide range of experimental investigations. Based on the previous theoretical and experimental studies the input variables considered in developing the ANNs model are outer diameter of column, compressive strength of unconfined concrete, length of column, wall thickness and tensile yield stress of steel tube. After the learning step, the neural network can be extracted the relationships between the input variables and output parameter. The criteria for stopping the training of the networks are Regression values and Mean Square Error. After constructing networks with constant input neurons but with different number of hidden-layer neurons, the best network was selected. The neural network results are compared with the existing models which showed the results are in good agreement with experiments.

## 1. Introduction

The two main types of composite column (Fig. 1) are the concrete filled steel tube column (CFST), where the steel is a rolled or built-up hollow section filled with concrete, and the steel reinforcement concrete (SRC) column, where the steel section is embedded or encased by the concrete [1]. Concrete-filled steel tube columns provide excellent structural benefits for seismic resistance such as high ductility and large energy absorption capacity [2]. In recent decades, there were a large number of studies carried out on circular concrete-filled steel tube (CCFST) columns [3-5]. Concrete

filled steel tubes are an economical column type, as the majority of the axial load is resisted by the concrete, which is less expensive than steel. Construction costs may be reduced due to the fast erection and an optimal design. Because of its higher strength, a composite column is lighter than a typical RC column with a similar strength, which reduces the loads on and cost of the foundation, the cost and amount of reinforcement bars, and thus the cost of construction. Due to steel tube location at the periphery of the cross section, the steel in CCFST has an optimal distribution that increases the strength and stiffness of the

member. The steel column section adds confinement to the concrete core, which induces an increment in strength and ductility in the concrete. This confinement is also influenced by the diameter-to-thickness ratio of the tubes.

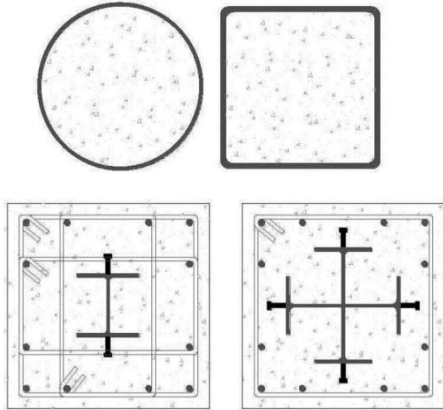

Fig. 1. Cross section configuration in composite members [1].

## 2. Artificial Neural Network

An artificial neural network (ANNs) is an information processing tool that is inspired by the way biological nervous systems, process the information. The key element of this tool is the novel structure of the information processing system. An ANNs is configured for a specific application, such as pattern

recognition or data classification, through a learning process. Learning in biological systems involves adjustments to the synaptic connections that exist between the neurons; the same process happens in ANNs. A biological neuron has major parts which are of particular interest in understanding an artificial neuron and include: dendrites, cell body, axon, and synapse (Fig. 2). A neuron is an electrically excitable cell that processes and transmits information by electrical and chemical signaling. Chemical signaling occurs via synapses, specialized connections with other cells. Neurons connect to each other in order to form neural networks. A neuron with a single R-element input vector is shown in Fig. 3. In this figure the individual element inputs ( $p_1, p_2 \dots p_R$ ) are multiplied by weights ( $w_{1,1}, w_{1,2}, \dots w_{1,R}$ ) and the weighted values are fed to the summing junction. The neuron has a bias  $b$ , which is summed with the weighted inputs to form the net input  $n$ . This sum,  $n$  (Eq. (1)), is the argument of the transfer function  $f$ .

$$n = w_{1,1}p_1 + w_{1,2}p_2 + \dots + w_{1,R}p_R + b \tag{1}$$

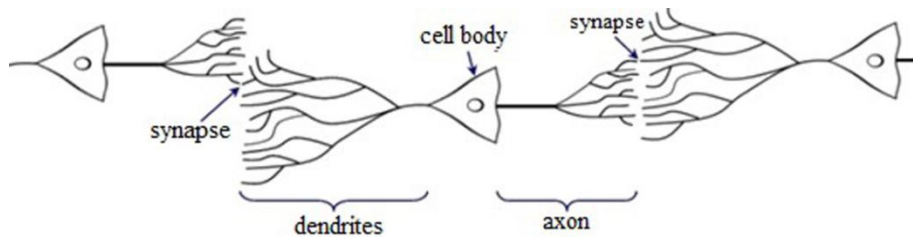

Fig. 2. Schematic of a biological neuron [6]

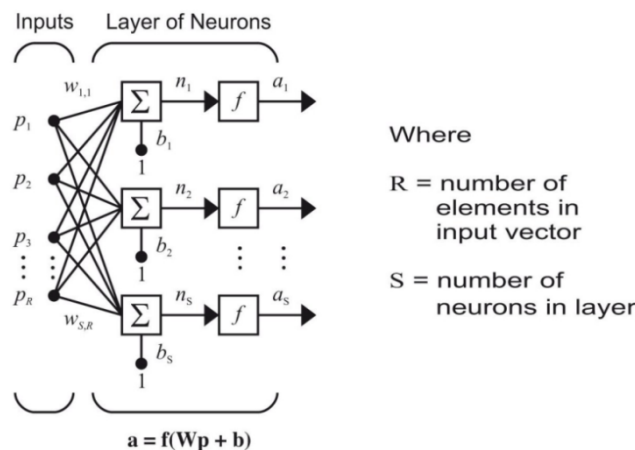

Fig. 3. Schematic of a neuron model [7].

### 3. Proposed ANN model for the prediction of compressive strength of confined concrete

As the first step for providing sufficient information for training, verifying and testing of neural networks, a comprehensive set of test results on the axial compressive strength of circular concrete filled steel tube specimens was collected [8-30]. All together, the selected database contains more than 150 test results including significant test programs of four recent decades.

Under axial compressive loads, composite interaction in CCFST columns, inducing hoop stresses in the steel tube and confining pressure in the concrete core (Fig. 4). Even in uniaxial loading, the concrete core is under a three-dimensional state of stress while the steel tube is under two-dimensional state of stress. The confinement pressure serves to increase both the strength and ductility of the concrete core.

Where  $f_1$  is the confining pressure in the concrete core,  $D$  is the outside diameter of the steel tube,  $t$  is the thickness of the steel tube, and  $\sigma_\theta$  is the hoop stress in the steel tube. In this study, the vertical compressive as 0.89 of yield stress of steel tubes [27].

In this study, a multi-layered feed-forward is used and trained with the error back propagation for the prediction of compressive strength of confined concrete. Back-propagation is the generalization of the Widrow-Hoff learning rule to multiple-layer networks and nonlinear differentiable transfer functions. A network includes biases, two sigmoid layers, and a linear output layer which is capable of approximating any function with a finite number of discontinuities. The term back-propagation refers to the manner in which the gradient is computed for nonlinear multilayer networks.

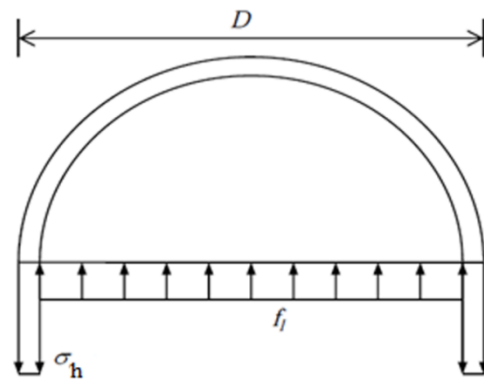

Fig. 4. Idealized Free Body Diagram of a CCFT Section [31].

The network which is used in this study is composed of two layers with Log-Sigmoid transfer function in the hidden layer and pure liner transfer function in the output layer. Also Levenberg-Marquardt algorithm used for training. One iteration of back-propagation algorithm is given by Eq. (2),

$$X_{k+1} = X_k - \alpha_k g_k \quad (2)$$

Where  $X_k$ , is a vector of current weights and biases,  $g_k$ , is the current gradient, and  $\alpha_k$ , is the learning rate.

Mean square error (MSE) was used for the initial criterion for stopping the training process of the networks. MSE is average of squared errors between target and estimated values and computed from following equations in which best value is zero.

$$\Delta = t - E_{st} \quad (3)$$

$$MSE = Average \left[ \sum_{k=1}^{NT} \Delta_k^2 \right] \quad (4)$$

Where,  $t$ ,  $E_{st}$ ,  $\Delta$  and  $k$  are target data, estimated values, error and number of output of network respectively. Other criterion is regression values that measured the correlation between targets and network outputs in the network, in which regression value of 1 means a close relationship and zero means a random relationship. To obtain well network both criterions were utilize.

Input data for network training include of:

- Compressive strength of unconfined concrete ( $f_c$ ),
- Length of column (L),
- Outer diameter of column (D),
- Wall thickness of steel tube (t),
- Tensile yield stress of steel tube (Fy).

Network output is steel-confined compressive strength of concrete ( $f_{cc}$ ). The number of hidden nodes was set to start the training of the ANNs networks. It was suggested by Berke and Hajela (1991) that the number of hidden nodes should be the average and the sum of the nodes on the input and output layers. In addition, Rogers and Ramarsh (1992) suggested that the good initial guess for hidden nodes was to take the sum of nodes on the input and output layers.

Lastly, Soemardi (1996) suggested that it should be 75% of the input nodes. Through the previously mentioned suggestions, the number of hidden nodes in this paper was set from 3 to 12 hidden nodes. In each network,

input vectors and targets randomly are divided into three sets and are:

- 60% used for training,
- 20% used to validate the network,
- 20% used as an independent test of network.

The regression values and maximum squared error of the networks with different number of hidden nodes are presented in Figs. 5 and 6. After the pre-acceptance of desirable networks, the best network is Net-6-2. In best network number of hidden neurons is six. The results for regression, training state and performance of Net-6-2 are presented in Figs. 7-9. The simulated compressive strengths of the steel-confined concrete from idealized neural network (Net-6-2) are compared against the experimental data (Fig. 10), which showed a good and reasonable agreement. The average error for the ANN model for predicting the experimental results is equal to 10.02%. If there is perfect agreement between the model and experimental results, all the points will lie along the 45° line.

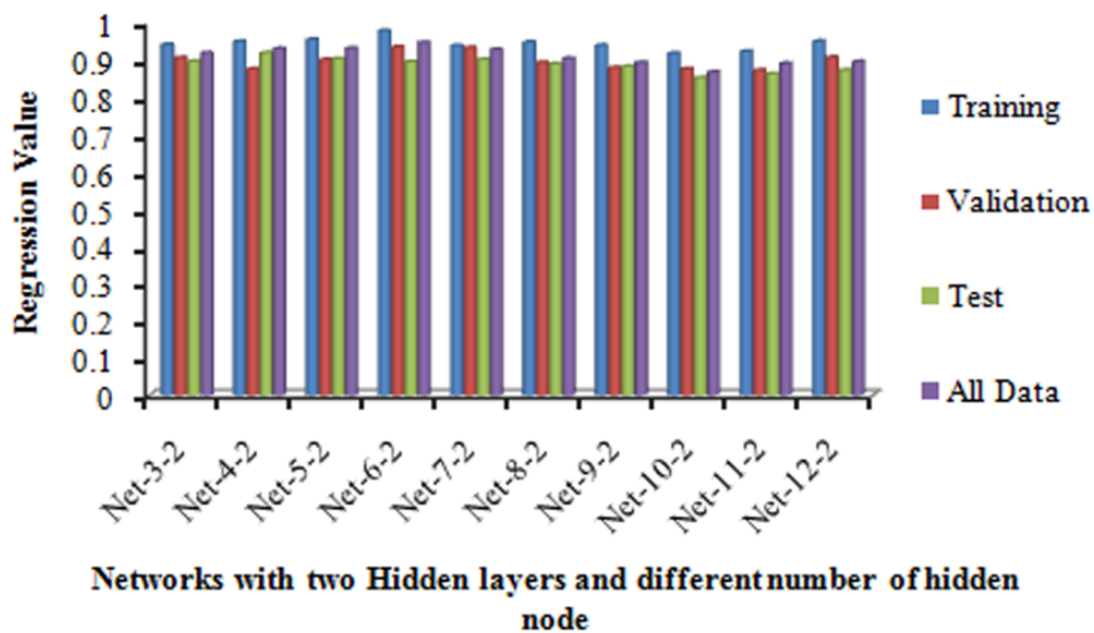

Fig. 5. Correlation coefficient of different networks.

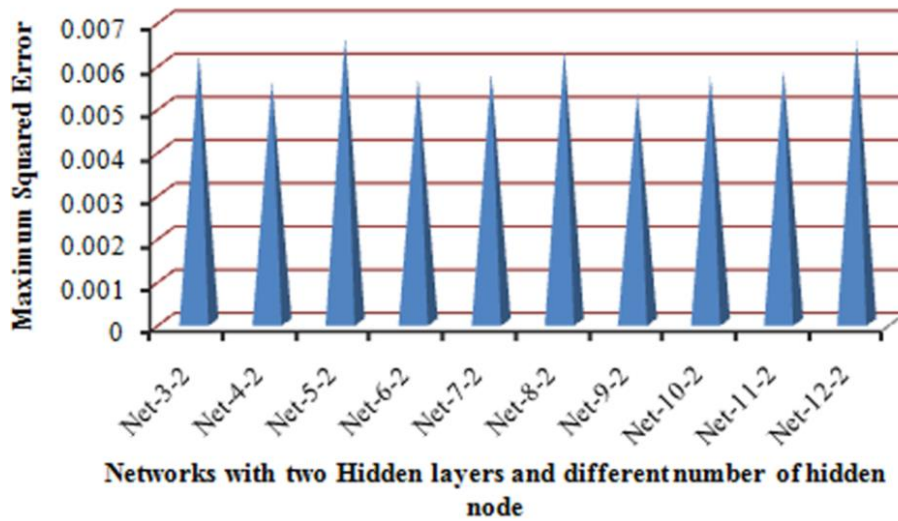

Fig. 6. Maximum Squared Error versus number of hidden layer neurons.

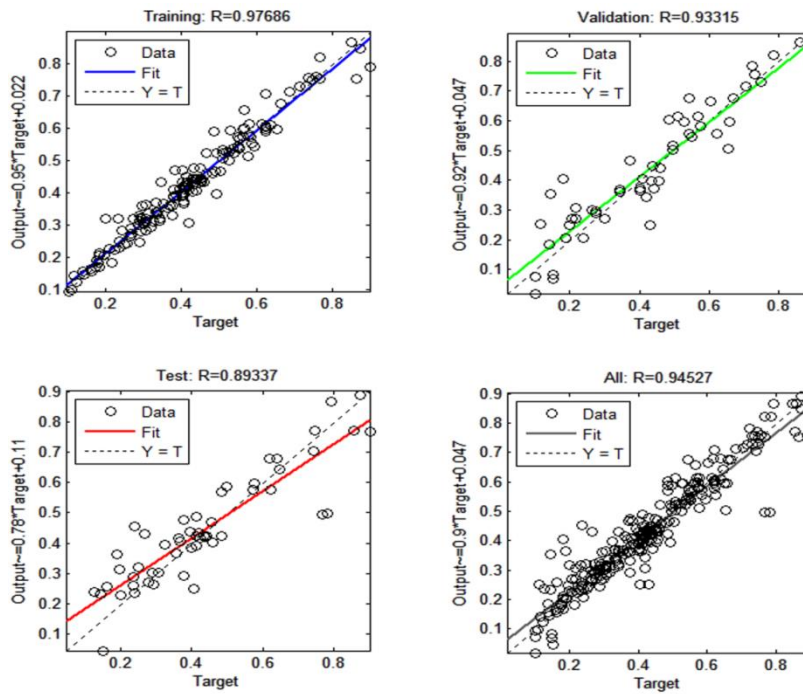

Fig. 7. Regression values of Net-6-2.

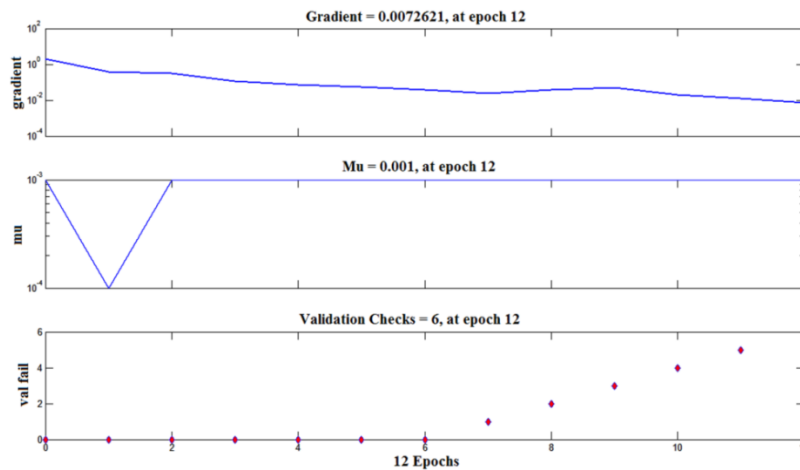

Fig. 8. Training State of Net-6-2

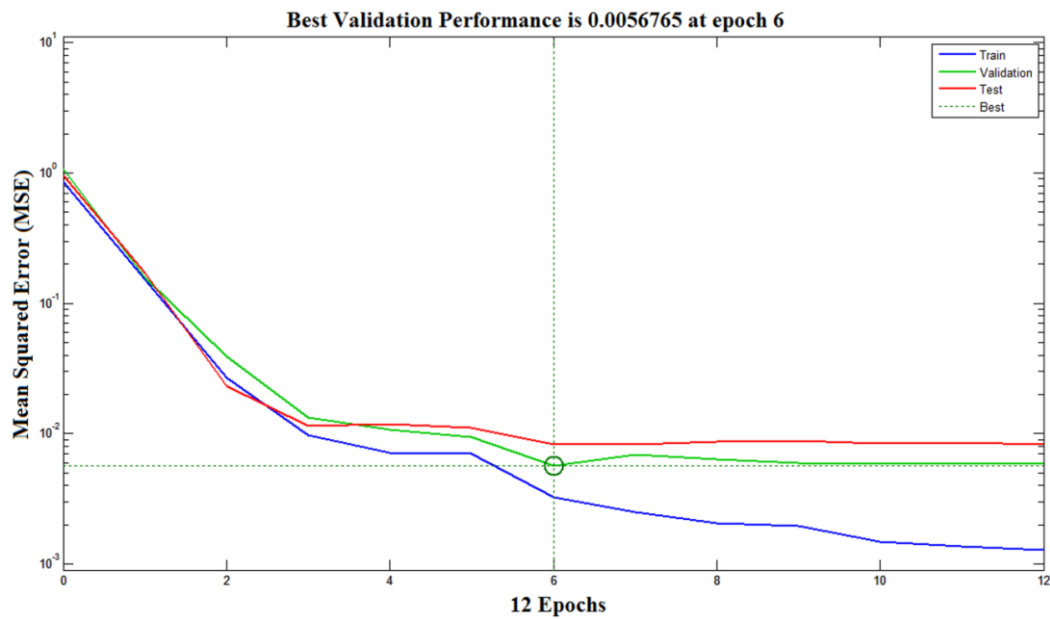

Fig. 9. Performance of Net-6-2.

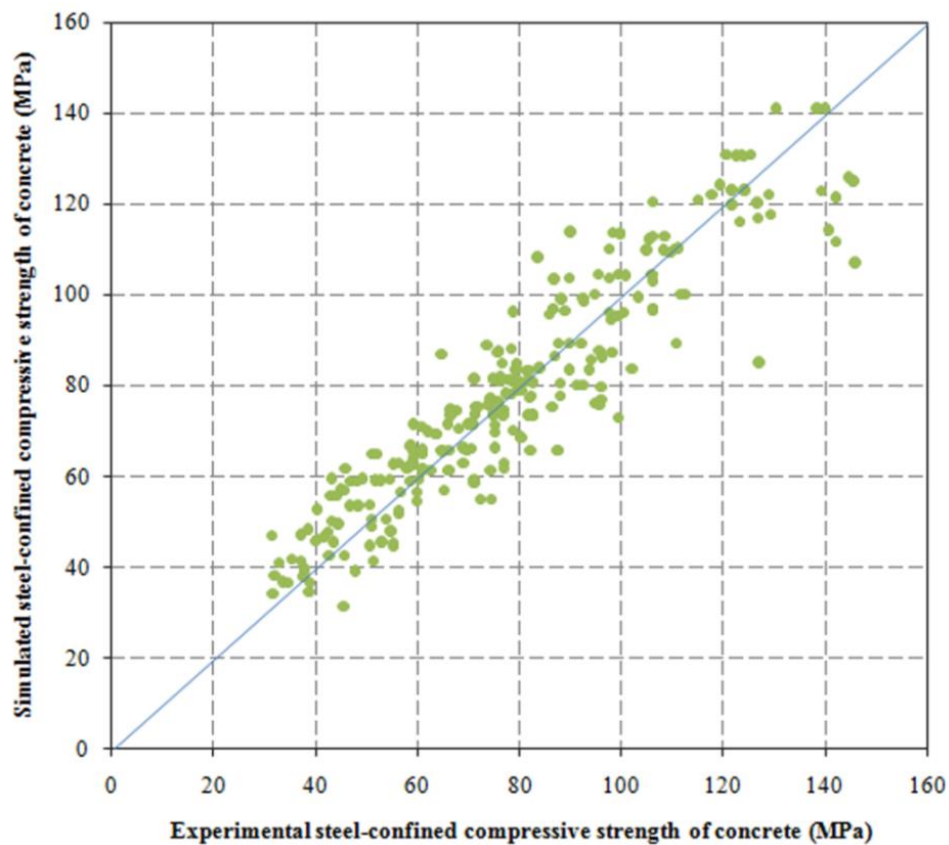

Fig. 10. Comparison of various predicted values of confined compressive strength versus experimental data.

#### 4. Conclusion

A large collection of studies carried out on circular concrete-filled steel tube columns was gathered in order to predict the behavior of the confined concrete using an intelligent system applying artificial neural networks. Having parameters used as input nodes in ANN modeling such as outer diameter of column, compressive strength of unconfined

concrete, length of column, wall thickness and tensile yield stress of steel tube. After training the 10 neural networks with different number of hidden neurons, by considering the regression values and mean squared error of the networks, one of the networks was selected for simulation which showed effective performance through training, testing, and validation. The average error for

the ANN model for predicting the experimental results is equal to 10.02%. The predicted behavior of the steel-confined columns was showed good agreement with the results of experimental data which indicated that the Net-6-2 network has learned to generalize the information well.

## REFERENCES

- [1] Kheyroddin, A., Naderpour, H., Ahmadi, M. (2013). "Performance of circular concrete filled steel tube members subjected to axial loading". Proceedings of the Fourth International Conference on Concrete & Development, Tehran, Iran.
- [2] Ding, F.X., Yu, Z.W., Gong, Y.Z. (2011). "Elasto-plastic analysis of circular concrete-filled stub columns". *Journal of Constructional Steel Research*, Vol. 67, pp. 1567-77.
- [3] Hatzigeorgiou, G.D. (2008). "Numerical model for the behavior and capacity of circular CFT columns, Part II: Verification and extension". *Journal of Engineering Structures*, Vol. 30, pp. 1579-89.
- [4] Susantha, K., Hanbin, G., Usami, T. (2001). "Uniaxial stress-strain relationship of concrete confined by various shaped steel". *Journal of Engineering Structures*, Vol. 23, pp. 1331-47.
- [5] Hu, H., Huang, C., Wu, M., Wu, Y. (2003). "Nonlinear analysis of axially loaded concrete-filled tube columns with confinement effect". *Journal of Structural Engineering*, Vol. 129, pp. 1322-1329.
- [6] Hu, Y.H., Hwang, J. (2001). "Handbook of neural network signal processing". CRC Press, USA.
- [7] Demuth, H. Beale, M., Hagan, M. (2009). "Neural network toolbox 6: User's Guide". Version 6.0.2. Mathworks, Inc.
- [8] Gardner, N.J., Jacobson, E.R. (1967). "Structural behavior of concrete filled steel tubes". *Journal of the American Concrete Institute*, Vol. 64, pp. 404-413.
- [9] Gardner, N.J. (1968). "Use of spiral welded steel tubes in pipe columns". *Journal of American Concrete Institute*, Vol. 65, pp. 937-942.
- [10] Knowles, R.B., Park, R. (1969). "Strength of concrete filled steel tubular columns". *Journal of Structural Division*, Vol. 95, pp. 2565-2587.
- [11] Zhanshuan, C.S.J. (1984). "Behavior and ultimate strength of short concrete-filled steel tubular columns". *Journal of Building Structures*, China Academy of Building Research.
- [12] Kitada, T., Yoshida, Y., Nakai, H. (1987). "Fundamental study on elastoplastic behavior of concrete encased steel short tubular columns". *Memoirs of the Faculty of Engineering*, Osaka City University, Osaka, Japan, Vol. 28, pp. 237-253.
- [13] Tomii, M., Xiao, Y., Sakino, K. (1988). "Experimental study on the properties of concrete confined in circular steel tube". *Proceedings of the International Specialty Conference on Concrete Filled Steel Tubular Structures*, Harbin, China, pp. 24-30.
- [14] Tsuji, B., Nakashima, M., Morita, S. (1991). "Axial compression behavior of concrete filled circular steel tubes". *Proceedings of the Third International Conference on Steel-Concrete Composite Structures*, Wakabayashi, M (ed.), Fukuoka, Japan, Association for International Cooperation and Research in Steel-Concrete Composite Structures, pp. 19-24.
- [15] Luksha, L.K., Nesterovich, A.P. (1991). "Strength testing of large-diameter concrete filled steel tubular members". *Proceedings of the Third International Conference on Steel-Concrete Composite Structures*, Wakabayashi, M. (ed.), Fukuoka, Japan, Association for International Cooperation and Research in Steel-Concrete Composite Structures, pp. 67-72.
- [16] Sakino, K., Hayashi, H. (1991). "Behavior of concrete filled steel tubular stub columns under concentric loading". *Proceedings of the Third International Conference on Steel-Concrete Composite Structures*, Wakabayashi, M. (ed.), Fukuoka, Japan, Association for International Cooperation

- and Research in Steel- Concrete Composite Structures, pp. 25-30.
- [17] O'Shea, M.D., Bridge, R.Q. (2000). "Design of circular thin-walled concrete-filled steel tubes". *Journal of Structural Engineering*, Vol. 126, pp. 1295-1303.
- [18] Kang, H.S., Lim, S.H., Moon, T.S. (2002). "Behavior of CFT stub columns filled with PCC on concentrically compressive load". *Journal of the Architectural Institute of Korea*, Vol. 18, pp. 21-28.
- [19] Giakoumelis, G., Lam, D. (2004). "Axial capacity of circular concrete-filled tube columns". *Journal of Constructional Steel Research*, Vol. 60, pp. 1049-1068.
- [20] Han, L.H., Yao, G.H. (2003). "Behavior of concrete-filled hollow structural steel (HSS) columns with pre-load on the steel tubes". *Journal of Constructional Steel Research*, Vol. 59, pp. 1455-1475.
- [21] Han, L.H., Yao, G.H. (2003). "Influence of concrete compaction on the strength of concrete-filled steel RHS columns". *Journal of Constructional Steel Research*, Vol. 59, No. 6, pp. 751-767.
- [22] Naderpour, H., Kheyroddin A., Ghodrati Amiri, G. (2010). Prediction of FRP-Confined Compressive Strength of Concrete Using Artificial Neural Networks, *Composite Structures* (Elsevier), Vol. 92, pp. 2817-2829.
- [23] Kheyroddin, A., Naderpour, H., (2008). "Nonlinear finite element analysis of composite RC shear walls". *Iranian Journal of Science & Technology*, Volume 32, No. B2, pp. 79-89.
- [24] Kheyroddin, A., Hoseini Vaez, S.R., and Naderpour, H. (2008). "Numerical Analysis of Slab-Column Connections Strengthened with Carbon Fiber Reinforced Polymers", *Journal of Applied Sciences*, Volume 8, No 2, pp. 420-431.
- [25] Kheyroddin, A., Naderpour, H. (2007). "Plastic Hinge Rotation Capacity of Reinforced Concrete Beams", *International Journal of Civil Engineering (IJCE)*, Volume 5, No.1.
- [26] Naderpour, H., Kheyroddin A., Ghodrati Amiri, G. (2010). "Prediction of FRP-Confined Compressive Strength of Concrete Using Artificial Neural Networks", *Composite Structures* (Elsevier), Vol. 92, pp. 2817-2829.
- [27] Sakino, K., Nakahara, H., Morino, S., Nishiyama, I. (2004). "Behavior of centrally loaded concrete-filled steel-tube short columns". *Journal of Structural Engineering*, Vol. 130, pp. 180-188.
- [28] Zeghiche, J., Chaoui, K. (2005). "An experimental behavior of concrete-filled steel tubular columns". *Journal of Constructional Steel Research*, Vol. 61, No. 1, pp. 53-66.
- [29] Oliveira, W.L.A. (2008). "Theoretical-experimental analysis of circular concrete filled steel columns". Doctoral thesis. São Carlos School of Engineering, University of São Paulo.
- [30] Uy, B., Tao, Z., Han, L.H. (2011). "Behavior of short and slender concrete-filled stainless steel tubular columns". *Journal of Constructional Steel Research*, Vol. 67, pp. 360-378.
- [31] Denavit, M.D., Hajjar, J.F. (2010). "Nonlinear seismic analysis of circular concrete-filled steel tube members and frames". Report No. NSEL-023, Newmark Structural Laboratory Report Series (ISSN 1940-9826), Department of Civil and Environmental Engineering, University of Illinois at Urbana-Champaign, Urbana, Illinois, March.