



journal homepage: <http://civiljournal.semnan.ac.ir/>

## Evaluation of the Seismic Response of Single-Story RC Frames under Biaxial Earthquake Excitations

**M. Jalilkhani<sup>1\*</sup>, M. Babaei<sup>2</sup> and S. Hooman Ghasemi<sup>3</sup>**

1. Assistant Professor, Engineering Faculty of Khoy, Urmia University, Urmia, Iran.

2. Assistant Professor, Bonab University, Bonab, Iran.

3. Assistant Professor, Qazvin Branch, Islamic Azad University, Qazvin, Iran.

Corresponding author: [m.jalilkhani@urmia.ac.ir](mailto:m.jalilkhani@urmia.ac.ir)

### ARTICLE INFO

Article history:

Received: 05 February 2020

Accepted: 07 April 2020

Keywords:

RC moment-resisting frame,  
Displacement demand,  
Shaking-table test,  
Nonlinear dynamic analysis,  
Biaxial excitation.

### ABSTRACT

This paper summarizes the lessons learned from a full-scale test on two RC frame prototypes that have recently been tested on LNEC shaking-table using four pairs of biaxial synthetic ground motion records during 15WCEE Conference (2012). The reference structures are two single-story RC frames which are geometrically identical but with different reinforcement details. The simplified inelastic models including 'one-component' inelastic elements with lumped plastic hinges at their ends are used to model the reference structures. The displacement demands of the RC frames are determined by using the nonlinear dynamic analyses and then compared with the exact test results for four different seismic hazards (intensities). In the initial pre-test analyses, the modeling parameters and deformation capacities for each RC element are determined using ASCE/SEI 41-13 standard. However in the post-test studies, the experimental equations developed by Panagiotakos and Fardis (2001), Haselton and Deierlein (2008) are used to obtain more accurate structural responses. A detailed comparison is carried out between the analytical results with those given by the tests. The results clearly show that there is fairly good agreement between the analytical and test results. The simplified inelastic modeling techniques are also identified accurate enough in estimating the seismic response of RC buildings under biaxial excitations.

## 1. Introduction

The seismic response of RC Moment Resisting Frames (MRFs) is typically

controlled by the flexural deformations of the frame (beam and column) members. These structural systems often provide sufficient lateral stiffness and ductility under the

seismic loads, and dissipate the excessive earthquake-induced demands by the formation of plastic hinges in the frame members. This causes the sudden brittle shear failure mode of the frame members to be replaced with the ductile flexural one [1].

The nonlinear seismic response of RC MRFs can currently be estimated by using various modeling techniques [2–3]. The simplified ‘one-component’ inelastic structural models such as that proposed by Ibarra *et al.* [4] are now considered as the simplest technique available in the literature. In these structural models, the inelastic deformations of the elements are concentrically assumed at their ends, and characterized by a multi-linear (bilinear or trilinear) moment-rotation ( $M-\theta$ ) relationship. As shown in the previous studies [5-7], this type of modeling technique can reliably predict the critical seismic demands of RC buildings if an accurate estimate of both elastic and inelastic properties of the structural components is included. This can also efficiently decrease the computational efforts compared to those required in the structural models with the distributed plasticity attributes [8]. Hence, the seismic demands obtained by the simplified ‘one-component’ inelastic models are strongly influenced by the strength and stiffness properties adopted for the structural components. As a result, these structural parameters are required to be estimated with more accuracy. It is noted that there are now some valuable experimental databases in the literature (e.g. Berry *et al.* [9], Panagiotakos and Fardis [10], Haselton and Deierlein [11], and Lignos and Krawinkler [12]) for calculating the nonlinear structural parameters of RC members. In addition, some of these parameters can alternatively be estimated using the equations specified by the building codes (e.g., ACI 318-14 [13])

until a reliable experimental database is available.

Within the framework of 15th World Conference on Earthquake Engineering (15WCEE), the structural response of two full-scale single-story RC frames was pseudo-dynamically investigated to discover the recent advancements in simulating the actual seismic behavior of RC buildings [14]. The reference structures are geometrically identical but with different reinforcement details and ductility levels. The frames are composed of typical RC beam-column connections and withstand the lateral loads using two RC MRFs along each primary direction. The gravity-load carrying system for each frame consists of a two-way RC slab with thickness of 0.1 m, monolithically spanning half of the story floor and provides a rigid diaphragm during the shaking-table tests. The reference structures are then subjected to four pairs of biaxial synthetic ground motion accelerations to study the dynamic response of RC frames for various seismic hazards (intensities). The base-movements are applied to the frames using LNEC 3D shaking table and the displacement time-history responses for two specific nodes (i.e., nodes A and B in Figure 1) are recorded during the tests. The results of this research can well provide the structural engineers with some valuable information about the advantages and disadvantages of using two different reinforcement details for RC members. In addition, the accuracy and efficiency of the simplified inelastic structural models in estimating the seismic displacement demand of RC MRFs can be evaluated by comparing the analytical and experimental test results.

In this study, simplified nonlinear mathematical models including inelastic

beam-column elements with lumped plastic hinges at their ends are used for simulating the reference structures. The seismic response of the reference structures is then determined using the nonlinear dynamic time-history analysis procedure in two separate phases of pre- and post-test analyses. Within the pre-test phase of parametric studies, the modeling parameters and the acceptance criteria for the structural components are determined using ASCE/SEI 41-13 standard [15]. However, because a direct comparison between the analytical and full-scale test results is required, the experimental equations proposed by Haselton and Deierlein [11] are used for more accurate estimation of the moment-rotation relationship of the columns in the post-test studies. Due to the lack of experimental data for RC beams, the same equations with zero axial force are used for calculating the strength and deformation capacities of the RC beam elements. The yield strength of the RC beam-column elements ( $M_y$ ) is also estimated using the empirical equations proposed by Panagiotakos and Fardis [10]. More details about the general configuration of the reference structures, together with the modeling assumptions used in this research will be presented in the subsequent section.

## **2. Description of the Frames and the Modeling Assumptions**

The reference RC frames (hereafter referred to as S-A and S-B frames) are composed of  $3.3 \times 3.8$  m centerline dimensions in plan, and are geometrically identical but with different reinforcement details. The story height and the clear length of the columns are 3.0 m and 2.6 m, respectively. The dead load equal to  $16.3 \text{ kN/m}^2$  is applied on the floor area. The frames have only a half of slab and the

gravity loads are applied on it. This may be due to the fact that the designer was aimed to deliberately produce an eccentricity between the mass and stiffness centers in these frames. This can cause the torsional effects are also contributed in the seismic response of the structures. The general configuration of the physical models prepared in the laboratory, together with the plan- and elevation-views, beam-column sections, and their reinforcement details have been shown in Figure 1.

A detailed description of the longitudinal reinforcement used in the beam members has also been provided in Figure 2. The most important issues about the reference structures can be outlined as follows: (1) in order to consider different ductility levels for the beam members, two different conventional and diagonal reinforcement orientations are selected for the beams in S-A and S-B structures, respectively; (2) to evaluate the effects of different stirrup spacing on the seismic lateral load capacity of the two prototypes, largely-spaced stirrups are selected for the RC members in S-A structure compared to those provided in S-B structure. Based on the results obtained from the tests on concrete and steel materials, the nominal (lower bound) compressive strength for the concrete material varies from 15.9 to 43.6 MPa for different members. The yield strength of the reinforcement also varies from 556 to 570 MPa. Because the tests are performed after a relatively short time after the construction, the mean strength values obtained from the samplings (i.e.,  $f_c=30.03$  MPa for beams, and  $f_c=35.63$  MPa for columns) are used as the 'unconfined' concrete strength properties for the seismic evaluation of the frames within the post-test analyses. The stress-strain relationship for both steel and concrete materials is

developed using Euro Code (EC8) standard [16]. The yield strength for all reinforcement is assumed as 561.67 MPa. More details

about the concrete and steel material properties can be found in 15WCEE blind test challenge report [14].

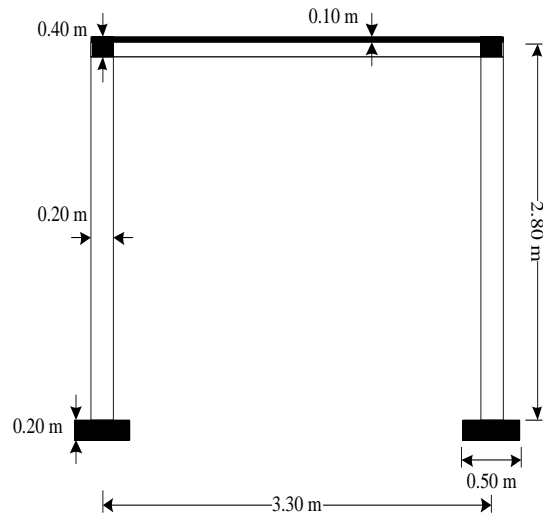

(a)

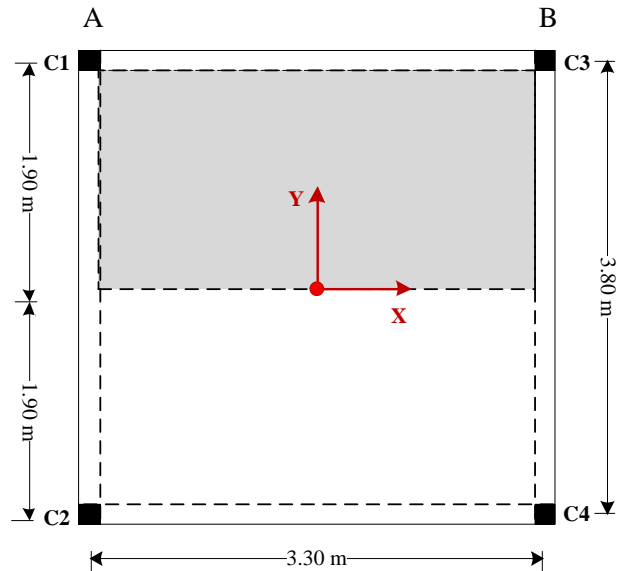
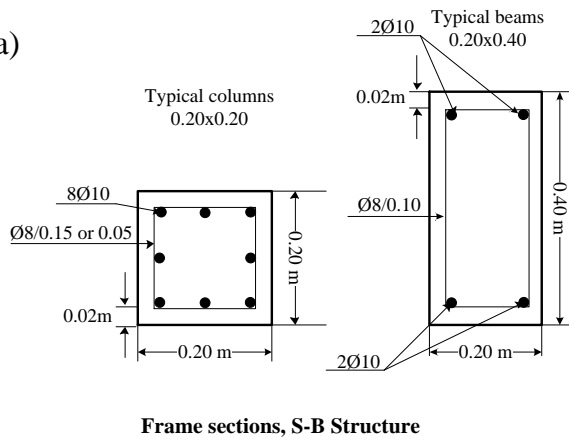

(b)

Frame sections, S-A Structure

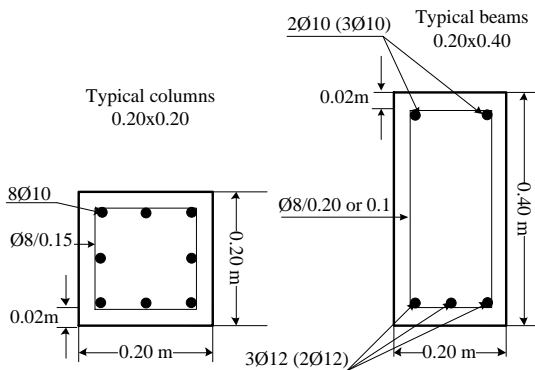

**Fig. 1.** General configuration of the reference structures (i.e. S-A and S-B frames): (a) full-scale (3D) and elevation views (b) plan-view, beam-column section dimensions and their reinforcement details [14].

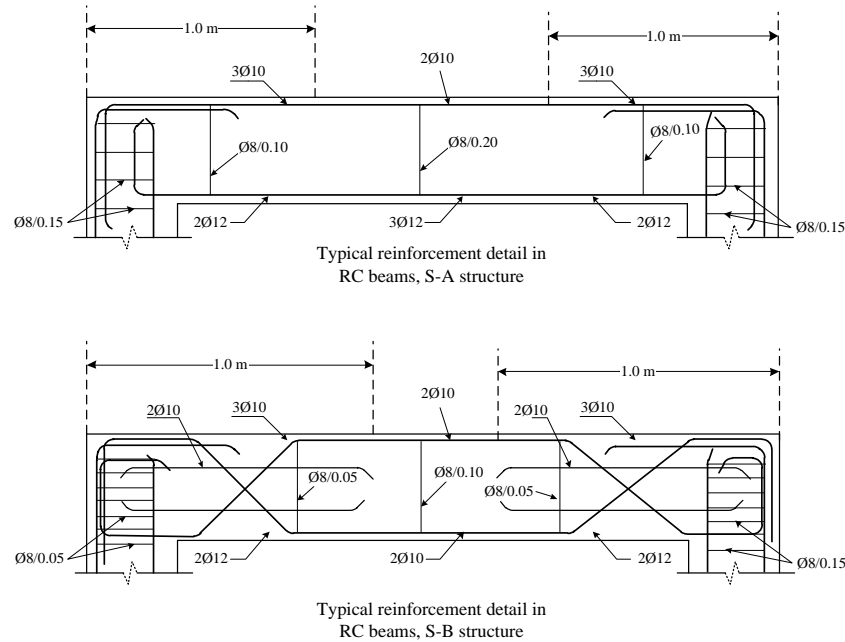

**Fig. 2.** The longitudinal reinforcement details for the typical RC beam members in S-A and S-B structures [14].

Simple structural models with the inelastic RC beam-column elements, composed of a quasi-elastic segment (i.e. segment with reduced stiffness properties) with one lumped plastic hinge at each end are used for the seismic nonlinear analysis of the frames [17]. In this study, due to the different reinforcement details used along the length of beam members, they are modeled using different inelastic elements. This may help us to estimate the seismic response of the reference structures with more accuracy. In the structural models, the inelastic flexural deformations for the beam elements are only assumed about the primary bending axis (M3), whereas the flexural hinges considering the interaction between the axial force and bending moments (P-M2-M3) are assigned to the column elements. Several cross-sectional analyses are also performed to accurately determine the interaction between the axial load and bending moments. In order to consider the actual size of the beam-column elements, the rigid connection

end zones are assigned to both ends of the frame members. This assumption can suitably prevent the joints from yielding in shear. The seismic excitations are applied to the structures using the LNEC shaking table and the base-movements. The columns are assumed to be fixed at the base and thus the base-movements are fully transmittable to the prototypes during the tests. The second-order (P- $\Delta$ ) effects are also considered in all cases. The cyclic-degradation properties of the beam elements are also considered using the results obtained from the tests performed by Popov *et al.* [18]. However, the effects of inelastic shear and torsional deformations, together with the strength-loss properties of the structural components are fully ignored. Based on the limited nonlinear analyses performed by the authors, a 5% Rayleigh damping ratio is found suitable for the nonlinear dynamic analysis of the structures under the weak seismic risk events. However, 0.5-2% Rayleigh damping ratio is selected for the stronger excitations, in which the

main energy dissipation is often due to the hysteretic characteristics of the structural components. In the preliminary parametric studies, the effective stiffness values for RC beam-column elements are assumed as 50% and 70% of the gross section properties, respectively [19]. According to the existing standards and guidelines (e.g. [20]), the effective stiffness values for RC beams often varies from 50% to 90% of gross section for high to low seismic intensities, respectively; whereas these values for RC columns are in the range of 35% to 65%. As shown in Section 4, the use of these effective stiffness values for RC beam-column elements leads to poor predictions of the seismic demands in the pre-test analyses. Thus, the effective stiffness values for RC elements ( $EI_e$ ) are modified within the post-test analyses using the empirical equation proposed by Haselton and Deierlein [17], as follows:

$$\frac{EI_e}{EI_g} = -0.02 + 0.98 \left[ \frac{P}{A_g f'_c} \right] + 0.09 \left[ \frac{L_s}{H} \right] \quad (1)$$

where  $P$  and  $L_s$  are the axial load and the shear span from the point of maximum moment to the inflection point (typically one-half of the member length), respectively.  $EI_g$  and  $A_g$  are the flexural stiffness and area of the gross column section, respectively.  $H$  is also the member depth. It is noted that Eq. (1) is valid for the  $EI_e$  values ranging from 0.35 to 0.80. The yielding rotation capacity of the plastic hinges is estimated by  $\theta_y = (L_s/3) \cdot \phi_y$ , in which  $\phi_y$  is the yielding curvature. In this research, due to the high rate of confinement provided by the stirrups in the structural elements, the post-capping plastic rotation capacity ( $\theta_{cap}$ ) is assumed as 0.1 radian, for all elements [21]. According to FEMA P695 document [22], the maximum to yield moment ratio ( $M_c/M_y$ ) for beam-

column elements is also assumed equal to 1.13. The capacity (pushover) curves of the reference structures in each primary direction have been shown in Figure 3a. In the pushover analyses, the lateral load pattern proportional to the elastic first-mode shape is used in all cases. The nonlinear analyses are all conducted using the CSI PERFORM 3D software [23]. The simple 'one-component' inelastic mathematical models have also previously been used by other researchers for estimating the seismic demands of RC buildings [24]. As shown in these studies, this type of modeling technique is so sensitive to the moment-rotation relationship adopted for the plastic hinges. In the pre-test parametric studies, several simple inelastic models were developed to qualitatively investigate the effect of different modeling parameters on the final structural responses. After the release of test results, serious attempts have been made to enhance the structural responses by applying some modifications to the assumptions used for the preliminary models. The displacement-controlled analysis procedure proposed by Dolšek and Fajfar [25] is also used to evaluate the accuracy of the initial values selected for the structural parameters in the pre-test analyses. Since a direct comparison between the numerical and test results is intended, the empirical equations proposed by Panagiotakos and Fardis [10], Haselton and Deierlein [11] are used instead of the conservative parameters specified by ASCE/SEI 41-13 [15], in the post-test analyses.

### 3. Ground Motion Ensembles

Four pairs of synthetic ground motion accelerations (hereafter referred to as earthquakes with low-, medium-, reference-,

and high-intensities), compatible with the general configuration of EC8 elastic design response spectrum, are produced and used as the target-movement at the base of the reference structures in the orthogonal X and Y primary directions, simultaneously (see Figure 1a). These ground motions are generated for four different seismic hazards (intensities), corresponding to 20% (Low), 70% (Medium), 100% (Reference), and 200% (High) of a target ground motion. In this study, a ground motion record whose elastic response spectrum is compatible with the general configuration of the EC8 elastic design response spectrum is selected as the target ground motion. The selected records have different Peak Ground Accelerations (PGAs) and make the prototypes experience a wide range of inelastic deformations during the tests. An effective duration of 40.96 sec is assumed for all records. Each RC frame is subjected to the selected ground motion records and the displacement demands at two given points of the reference frames (i.e., A and B points; see Figure 1b) are recorded in the 0.005 sec intervals during the tests. The elastic response spectra of the ground motion records, together with the undamped EC8 elastic design response spectrum are shown

in Figure 3b. More details about the dynamic characteristics of the ground motion records along with the methodology used for the generation and modification of them can be found in 15WCEE blind test challenge report [14].

#### 4. Nonlinear Dynamic Analysis Results

In this section, the seismic demands of the RC frames are determined for each ground motion record using the nonlinear dynamic time-history analysis. The results are then compared to those obtained from the shaking-table tests. Due to the large number of dynamic analyses performed in this study, the displacement demands obtained from the pre- and post-test analyses are only presented and discussed. The estimation of other seismic demands and a full performance evaluation of the considered structures are beyond the scope of the present study.

The deformation and the plastic hinge distribution in S-A model at 17th second of the nonlinear dynamic time-history analysis have been shown in Figure 4 for different (i.e. low, medium, and high) seismic intensities.

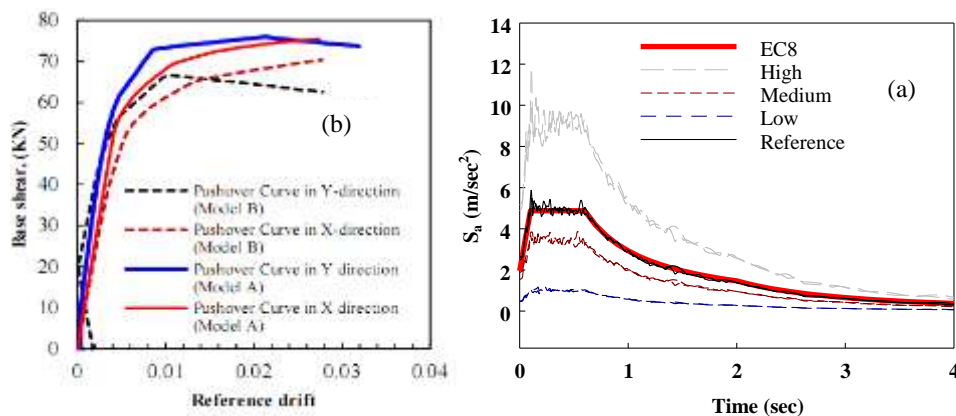

**Fig. 3.** (a) the elastic response spectra of the selected ground motion records, together with the EC8 elastic design response spectrum [14] (b) the pushover curves of the S-A and S-B models along each primary direction.

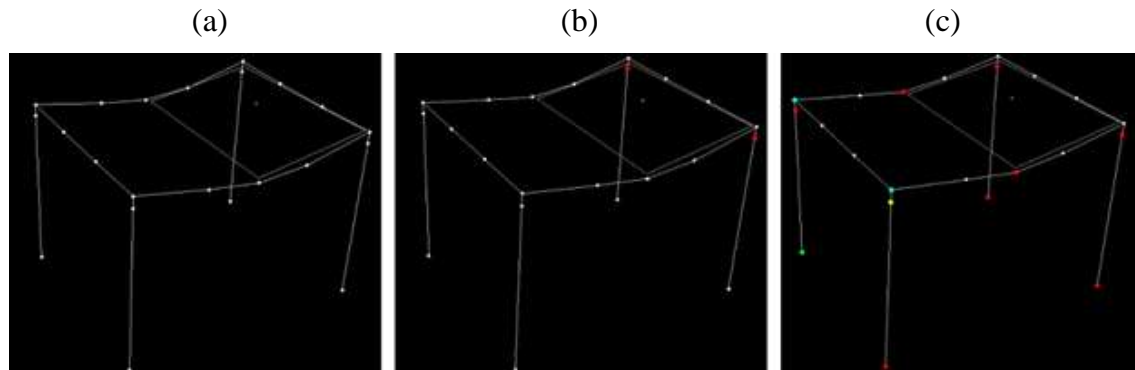

**Fig. 4.** The deformation and the plastic hinge distribution of S-A model at the 17th second of the nonlinear dynamic time-history analysis for the (a) low, (b) medium, and (c) high seismic intensities.

Figures 5 and 6 also show the lateral displacement time-histories at ‘point B’ of the S-A and S-B frames in the pre-test analyses. As can be seen from Figures 5 and 6, there is a fair agreement between the analytical results with those given by the tests. This discrepancy between the results may be attributed to the fact that the modeling parameters and the deformation capacities for the structural components have been determined based on the ASCE-41 standard in the pre-test studies. Because the damping ratio for a pseudo-dynamic test is equal to zero [6], a more realistic comparison between the numerical results with those given by the pseudo-dynamic tests can be performed when a zero damping ratio is selected for the numerical analyses, too. This can simply discover the differences between the peak seismic demands obtained from the pseudo-dynamic tests with those from the numerical analyses. However, this assumption is often more suitable for the stronger ground motions where the hysteretic dissipation is mainly controlled by the nonlinear behavior of the steel and concrete materials. Thus, in order to consider the energy dissipation capacity of the structural components prior to the yielding state, a Rayleigh damping ratio equal to 5% is selected for the first and third modes of the

reference structures. However, a try-and-error procedure is then used to select an appropriate value for the damping ratio (ranging from 0% to 5%) so that minimum the differences between the peak seismic demands obtained by the pseudo-dynamic tests and numerical analyses. The parametric analyses clearly show that a Rayleigh damping ratio ranging from 0.5% to 5% are more suitable for the selected ground motions (see Figures 7 and 8).

Figures 7 and 8 show the displacement demands obtained by the nonlinear dynamic analyses in the post-test studies for S-A and S-B structures for different seismic intensities, respectively. The deformation capacities for the structural components are determined using the experimental equations proposed by Haselton and Deierlein [11], Panagiotakos and Fardis [10]. The results obtained by the experimental tests are also presented for the sake of comparison. As can be seen from Figures 7 and 8, a good correlation between the displacement demands obtained by the dynamic analyses with those recorded during the tests can be observed. Except the high seismic intensity, the displacement demands can satisfactorily be estimated for the other seismic intensities. As a result, the ‘one-component’ lumped inelastic model can relatively good simulate



the basic inelastic dynamic response of RC MRFs under the seismic loads from low to moderate intensities (hazards). However, the response of this modeling technique is

strongly influenced by the modeling parameters and deformation capacities adopted for the structural components.

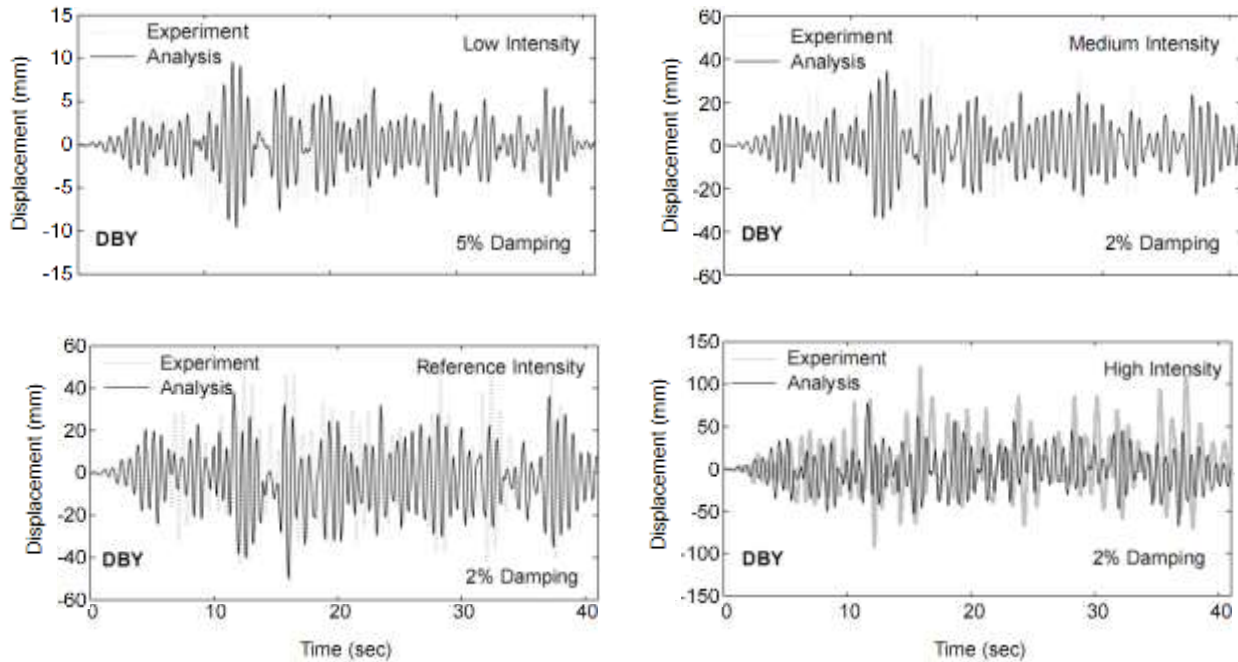

**Fig. 5.** The displacement demands obtained by the nonlinear dynamic analyses together with those recorded during the tests at point 'B' of S-A structure in the pre-test studies (DBY is the 'B' point displacement demand along the Y direction).

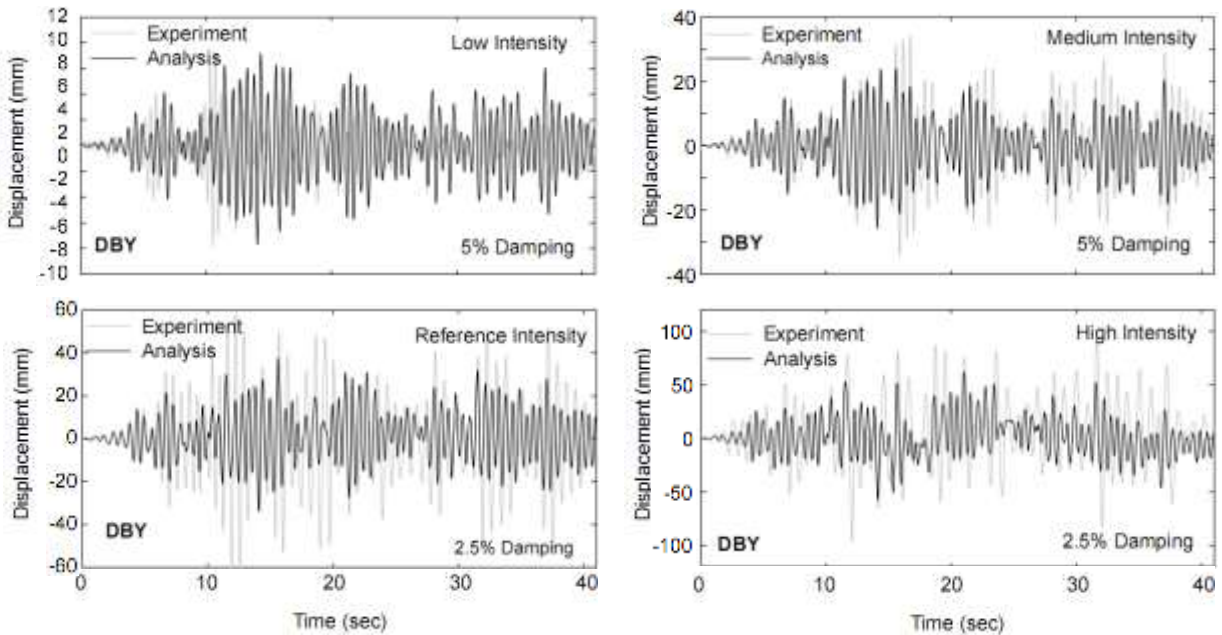
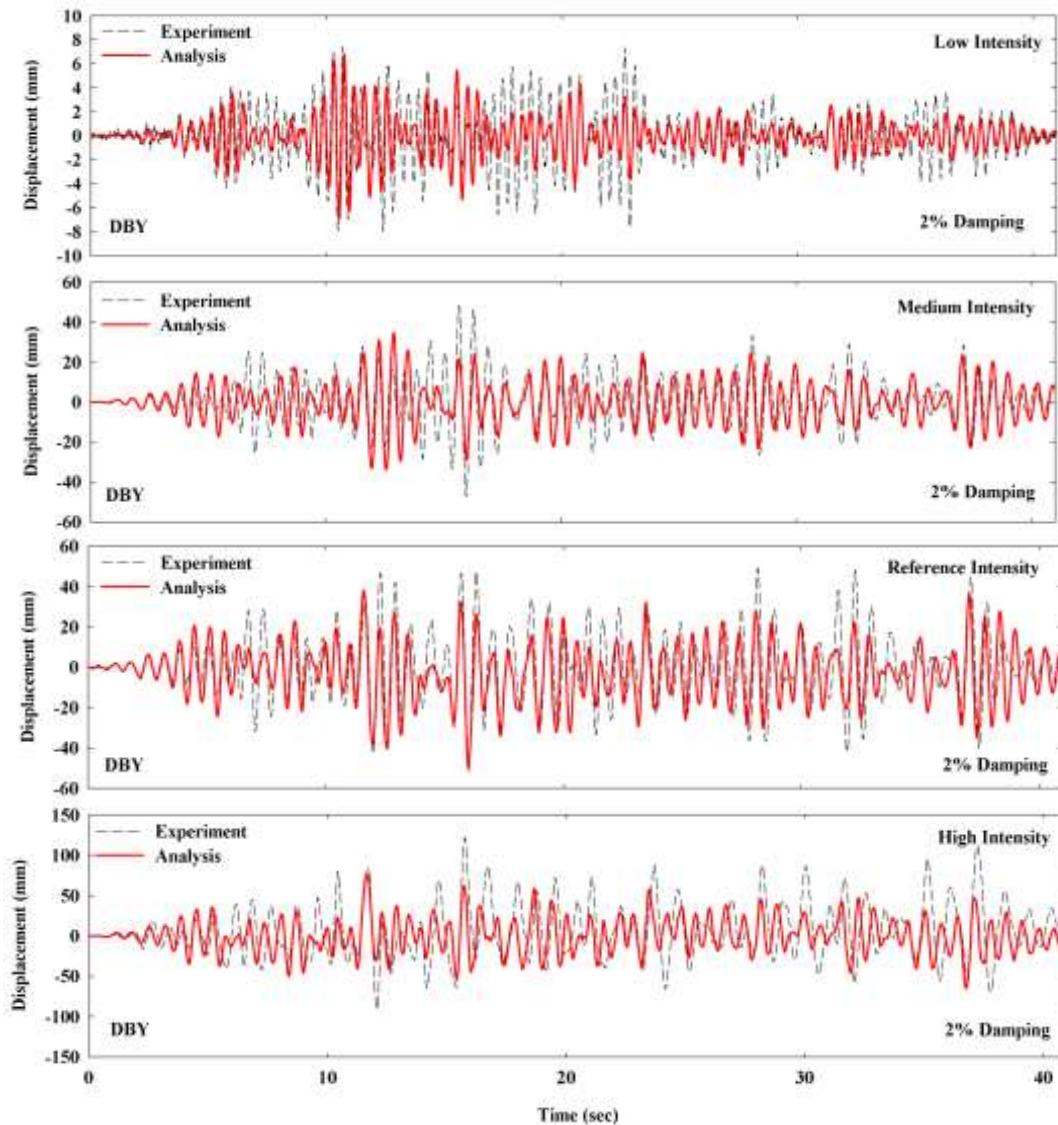

**Fig. 6.** The displacement demands obtained by the nonlinear dynamic analyses together with those recorded during the tests at point 'B' of S-B structure in the pre-test studies (DBY is the 'B' point displacement demand along the Y direction).

## 5. Conclusions

In this paper, the seismic response of two single-story RC MRFs, designed based on

the EC8 design requirements was analytically estimated and compared with the shaking-table test results.



**Fig. 7.** The displacement demands obtained by the nonlinear dynamic analyses together with those recorded during the tests at point 'B' of S-A structure in the post-test studies; (DBY is the 'B' point displacement demand along the Y direction).

Some attempts have also been made by the authors to study the accuracy and efficiency of the commonly used simplified inelastic modeling techniques in predicting the seismic response of RC buildings. The analysis results were presented in two

separate parts of pre- and post-test analyses. Despite the given ground motion inputs, the analysis results clearly showed that the blind pre-test predictions are not satisfactory, and they include many source of uncertainties. The pre-test analyses can only provide a fair

prediction of the global response of the example structures. However, they are unable to properly estimate many important features

of the structure such as the distribution of the damage in the beam-column elements. It is noted that the

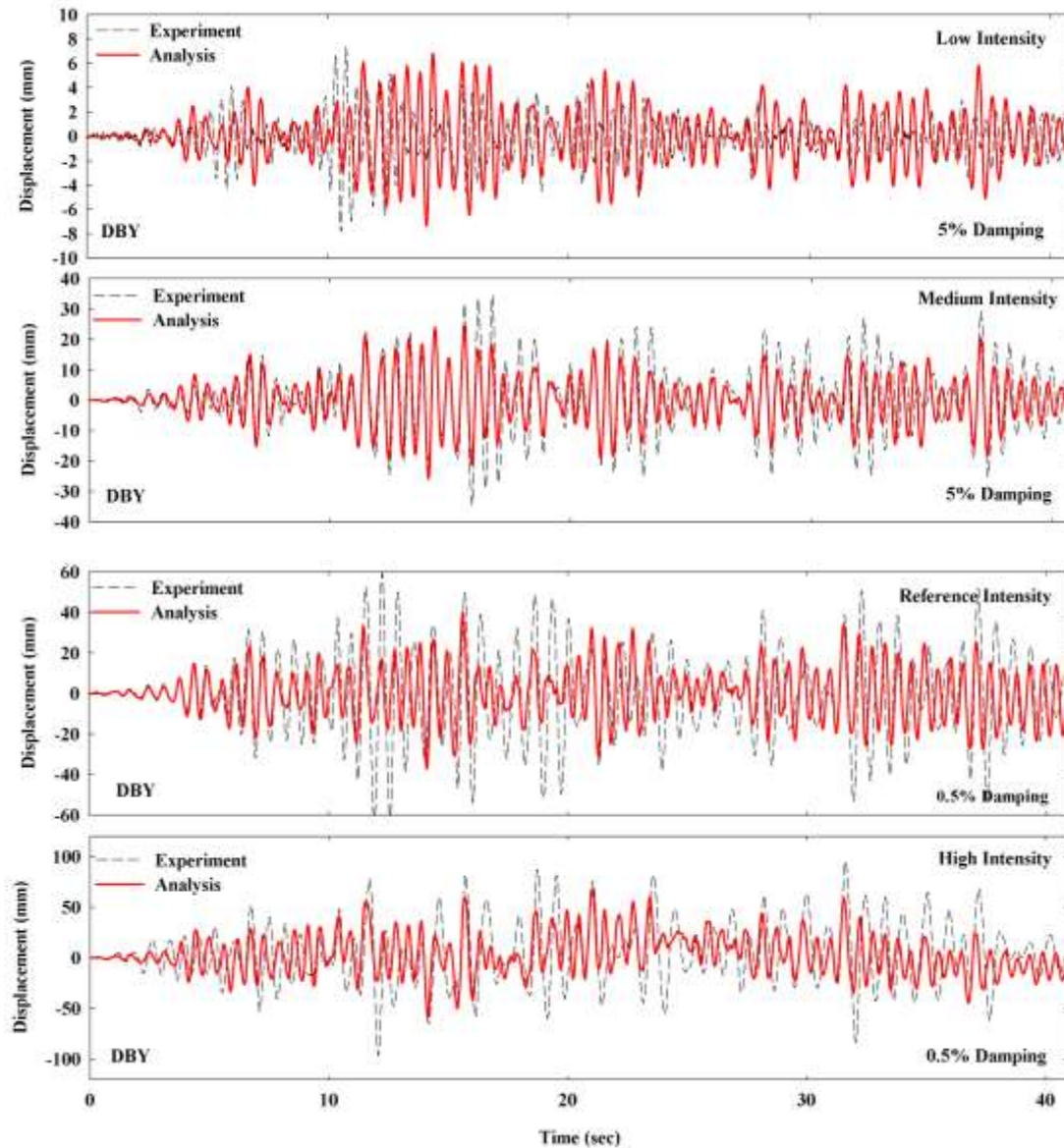

**Fig. 8.** The displacement demands obtained by the nonlinear dynamic analyses together with those recorded during the tests at point 'B' of S-B structure in the post-test studies; (DBY is the 'B' point displacement demand along the Y direction).

formation of the plastic mechanism is extremely sensitive to the details of the mathematical model. Nonetheless, the structural responses can be improved by adapting some of the parameters and simulate all the important features of the observed structural responses.

In the pre-test analyses, the modeling parameters and the deformation capacities for the structural components were determined based on the ASCE-41 requirements. However for the post-test analyses, these structural parameters were obtained using the empirical equations developed based on a

large number of experimental tests. In spite of various uncertainties and complexities involved in the nonlinear modeling of RC structures, the simple one-component lumped inelastic modeling technique was found relatively good for predicting the inelastic response of the example RC MRFs for different seismic intensities. According to the obtained results (see Figures 7 and 8), the structural models developed in this study can relatively good predict the inelastic response of RC frames. However, there are still some meaningful discrepancies between the analytical and test results that are mainly attributed to the approximations and simplifications used in the structural models. For example, the buckling and slippage of the longitudinal bars are highly probable in the case of the severe ground motion events, and these phenomena should properly be taken into account in the mathematical models. However for the simplicity, all these effects were totally ignored in the current study.

In the post-test analyses, some improvements were also observed in the final structural responses when the empirical equations proposed by Haselton and Deierlein [11], and Panagiotakos and Fardis [10] were used for estimating the strength and deformation capacities of RC members. These equations were also verified in this paper for the example structures. Nonetheless, the estimation of the damping ratio for the reinforced concrete structures, together with the contributions of inelastic shear and torsional deformations in the final structural responses were still remained unclear and need further research. It is worth mentioning that the structural responses can be improved by the modification of the modeling parameters and using several inelastic elements rather than one single element.

The simple one-component lumped inelastic modeling technique was confirmed to be reliable and efficient. The typical computing time for a nonlinear dynamic time-history analysis was measured about 2 minutes on a PC with an Intel Pentium 4 processor (3.0 GHz, 512 MB RAM). The shaking-table tests and numerical simulations can suitably increase the engineering judgement in the practical applications, which is often required in the mathematical modeling of the complex RC buildings. Because the accuracy of the analysis results is often controlled by large uncertainties and the randomness of the input parameters, more sophisticated models do not necessarily provide more reliable results.

It is impossible to make general conclusions and recommendations for the mathematical modeling of RC MRFs, based on two shaking-table tests. The seismic evaluation of RC MRFs is a challenging task and requires a deep understanding of the actual behavior of RC components under the seismic loads. A wise combination of the analytical results with the lessons learned from the experimental tests may provide the best guideline for the seismic performance assessment of RC buildings.

## REFERENCES

- [1] Morales-Gonzalez, M., Vidot-Vega, AL. (2017) "Seismic response of reinforced concrete frames at different damage levels." *International Journal of Advanced Structural Engineering*, Vol. 9, pp. 63–77.
- [2] Otani, S. (2002). "Nonlinear earthquake response analysis of reinforced concrete buildings." *Lecture Notes, ROSE School, University of Pavia*.
- [3] Sousa, R., Almeida, JP., Correia, AA., Pinho, R. (2018) "Shake table blind prediction tests: contributions for improved fiber-based frame modelling." *Journal of*

- Earthquake Engineering, 10.1080/13632469.2018.1466743.
- [4] Ibarra, L.F., Medina, R.A., Krawinkler, H. (2005) "Hysteretic models that incorporate strength and stiffness deterioration." *Journal of Earthquake Engineering and Structural Dynamics*, Vol. 34, pp. 1489–1511.
- [5] Stratan, A., Fajfar, P., (2002) "Influence of modeling assumptions and analysis procedure on the seismic evaluation of reinforced concrete GLD frames." IKPIR Report, Institute of Structural Engineering, Earthquake Engineering and Construction IT (IKPIR), University of Ljubljana, Slovenia.
- [6] Fajfar, P., Dolšek, M., Marušić, D., Stratan, A. (2006) "Pre- and post-test mathematical modeling of a plan-asymmetric reinforced concrete frame building." *Journal of Earthquake Engineering and Structural Dynamics*, Vol. 35, pp. 1359–1379.
- [7] Giberson, M.F. (1967) "The response of nonlinear multi-story structures subjected to earthquake excitation." EERL Report, Earthquake Engineering Research Laboratory, California Institute of Technology, Pasadena.
- [8] Cuong, N.H., Kim, S.E., Oh, J.R., (2007) "Nonlinear analysis of space steel frames using fiber hinge concept." *Engineering Structures*, Vol. 29, pp. 649–657.
- [9] Berry, M., Parrish, M., Eberhard, M. (2004) "PEER structural performance database user's manual." Berkeley (CA): Pacific Engineering Research Center, University of California.
- [10] Panagiotakos, T.B., Fardis, M.N. (2001) "Deformations of reinforced concrete at yielding and ultimate." *ACI Structural Journal*, Vol. 98, pp. 135–147.
- [11] Haselton, C.B., Liel, A.B., Lange, S.T., Deierlein, G.G. (2008) "Beam-column element model calibrated for predicting flexural response leading to global collapse of RC frame buildings." PEER Report 2007/03, Pacific Engineering Research Center, University of California, Berkeley, California.
- [12] Lignos, D.G., Krawinkler, H. (2009) "Sidesway collapse of deteriorating structural systems under seismic excitations." Report no. TB 172. John A. Blume Earthquake Engineering Research Center. Stanford University: Palo Alto (CA).
- [13] ACI-318, Building code requirements for structural concrete (ACI 318-14) and Commentary (ACI 318R-14). American Concrete Institute: Farmington Hills, MI, 2014.
- [14] Costa, A., Campos-Costa, A., Candeias, P., Guerreiro, L., Mendes, L. (2012) "15WCEE blind test challenge - design report" Proc. of the 15th World Conference on Earthquake Engineering, Lisbon, Portugal.
- [15] ASCE-41, Seismic evaluation and upgrade of existing buildings (ASCE/SEI 41-13), American Society of Civil Engineers (ASCE), Reston, VA, 2013.
- [16] CEN. Eurocode 8, Design of structures for earthquake resistance, (2004), Part 1: general rules seismic actions and rules for buildings. EN 1998-1, CEN, Brussels.
- [17] Haselton, C.B., Deierlein, G.G. (2007) "Assessing seismic collapse safety of modern reinforced concrete moment-frame buildings." Report no. 156. John A. Blume Earthquake Engineering Research Center, Stanford University: Palo Alto (CA).
- [18] Popov, E.P., Bertero V.V., Krawinkler, H. (1972) "Cyclic behavior of three RC flexural members with high shear." Report No. EERC 72-5, Earthquake Engineering Research Center, University of California, Berkeley, California.
- [19] Goulet, C.A., Haselton, C.B., Mitrani-Reiser, J., Beck, J.L., Deierlein, G.G., Porter, K.A., Stewart, J.P., (2007) "Evaluation of the seismic performance of a code-conforming reinforced-concrete frame building—from seismic hazard to collapse safety and economic losses." *Earthquake Engineering and Structural Dynamics*, Vol. 36, No. 13, 1973–1997.
- [20] FEMA-273, NEHRP guidelines for the seismic rehabilitation of buildings, (1997),

- Building seismic safety council (BSSC), Washington (DC): Federal Emergency Management Agency.
- [21] Haselton, CB., Liel, AB., Deierlein, GG; Dean, BS., Chou, JH. (2011) "Seismic collapse safety of reinforced concrete buildings. I: assessment of ductile moment frames." *ASCE Journal of Structural Engineering*, Vol. 137, pp. 481–491.
- [22] FEMA-P695, Quantification of building seismic performance factors, (2008), ATC-63 Project Report, Applied Technology Council, Redwood City, CA, USA.
- [23] Computers & Structures Incorporated (CSI). *PERFORM 3D. Non-linear analysis and performance assessment for 3D structures*, (2006), CA, USA, Berkeley.
- [24] Bayhan B. (2013). "Numerical simulation of shaking table tests on 3D reinforced concrete structures." *Structural Engineering and Mechanics*, Vol. 48, pp. 151–171.
- [25] Dolšek, M., Fajfar, P., (2002) "Mathematical modeling of an infilled RC frame structure based on the results of pseudo-dynamic tests." *Journal of Earthquake Engineering and Structural Dynamics*, Vol. 31, pp. 1215–1230.